

COLLISION REPAIR INFORMATION

FOR THE COLLISION REPAIR PROFESSIONAL

TITLE: BODY & FRAME COMPONENT SECTIONING
SECTION: EXTERIOR BULLETIN # 155
MODELS: ALL TOYOTA, LEXUS, and SCION MODELS
DATE: REVISED SEPTEMBER 2013

Approved Weld-On Component Replacement Procedures

Weld-on component replacement procedures, including cut and join locations, welding specifications, illustrations, and instructions can be found in model-specific Repair Manuals for Collision Damage. Specifications provided are for new undamaged OE service parts. Visit the Toyota Technical Information System (TIS or www.techinfo.toyota.com) for repair manuals and technical information.

Precaution

In the case where an OE weld-on service component is available but installation specifications are not published, install the component at OE seams with Squeeze-Type Resistant Spot and/or Gas Metal Arc /Metal Inert Gas Welding methods.

Component Sectioning Procedures

Body Sectioning with salvage components is not an approved repair procedure. This position is reinforced in CRIB #122 Body Sectioning.

Frame Sectioning is considered partial replacement of a frame rail or component, which is not an approved repair procedure on Toyota and Lexus full frame vehicles. This position is reinforced in CRIB #136 Full Frame Repair & Component Replacement. For more detailed information on this and other important collision repair topics plan to attend Toyota/Lexus Collision Repair & Refinish Training. Visit www.crrtraining.com for training and registration information.

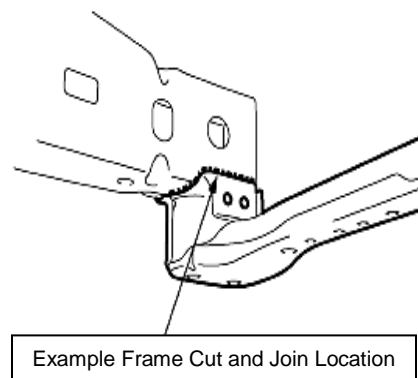
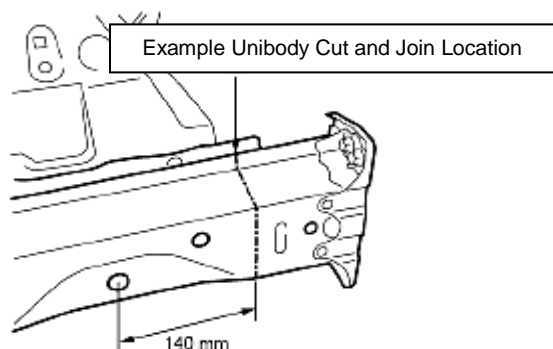

**PLEASE ROUTE THIS BULLETIN TO YOUR COLLISION REPAIR CENTER
MANAGER AND COLLISION REPAIR TECHNICIANS**